



光电耦合器

OPTOCOUPLER

产品规格书
Product Data Sheet

Si-304X, Si-306X, Si-308X 系列

Si-304X, Si-306X, Si-308X Series

Si DCC
Release

贵州硅耐光电有限公司

GuiZhou Silicon Nice Optoelectronic Co., Ltd.

描述 Description

Si-304X,Si-306X,Si-308X 系列器件是由一个 GaAs 红外发光二极管和一个单晶硅芯片的过零相位光电双向晶闸管组成的光电耦合器。

The Si-304X,Si-306X,Si-308X series devices are optocouplers composed of a GaAs infrared light emitting diode and a zero-crossing silicon chip random phase photoelectric bidirectional thyristor.

典型应用 Typical Applications

- 开关电源，智能电表
Switching power supply, intelligent meter
- 工业控制，测量仪器
Industrial control, measuring instruments
- 办公设备，比如复印机
Office equipment such as copiers
- 家用电器，比如空调、风扇、热水器等
Household appliances: such as air conditioners, fans, water heaters, etc.

特性 Features

- 高隔离电压 ($V_{ISO}=5000VRMS$)
High isolation 5000 VRMS
- 直流输入和过零触发输出
DC input with zero-cross photo triac output
- 工作温度: $-55^{\circ}C \sim 110^{\circ}C$
Operating Temperature: $-55^{\circ}C \sim 110^{\circ}C$

封装与功能图 Package and Functional Diagram

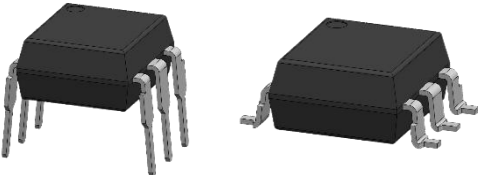
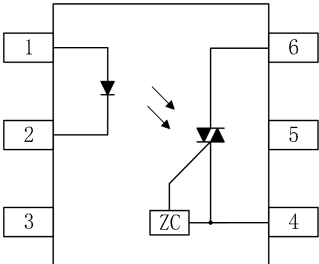
封装 Package	内部连接图 Internal Connection Diagram	引脚分配 Pin Assignment
 <p style="text-align: center;"> DIP6 SMD6 </p>		<p> 1: Anode 4:Terminal 2: Cathode 5: NC 3: NC 6: Terminal </p>



安规与绝缘参数 Safety and Insulation Ratings

参数 Parameter		符号 Symbol	数值 Value	单位 Unit
最大额定隔离电压 Maximum Rated Withstanding Isolation Voltage	According to UL1577, t = 1 min	V _{ISO}	500	V _{RMS}
最大瞬态隔离电压 Maximum Transient Isolation Voltage	According to DIN EN 60747-5-5	V _{IOTM}	7000	V _{peak}
最大峰值重复隔离电压 Maximum Repetitive Peak Isolation Voltage	According to DIN EN 60747-5-5	V _{IORM}	15000	V _{peak}
爬电距离 Creepage Distance	/	L	>7.0	mm

极限参数 Absolute Maximum Ratings (T_{amb}=25°C)

参数 Parameter		符号 Symbol	极限值 Rating	单位 Unit
输入端 Input	正向电流 Forward Current	I _F	50	mA
	反向电压 Reverse Voltage	V _R	6	V
	功耗 Power Dissipation	P	100	mW
	峰值电流 Peak forward current (1us, pulse)	I _{FP}	1	A
	结温 Junction Temperature	T _J	125	°C
输出端 Output	断态输出电压 Off-state Output Terminal Voltage	Si-304X	400	V
		Si-306X	600	
		Si-308X	800	
	峰值重复浪涌电流(pw=100μs,120pps) Peak repetitive surge current (pw=100μs,120pps)	I _{TSM}	1	A
	集电极功耗 Collector Power Dissipation	P _C	300	mW
	结温 Junction Temperature	T _J	125	°C
总功耗 Total Power Dissipation		P _{tot}	400	mW
工作温度 Operating Temperature		T _{amb}	-55~110	°C
存储温度 Storage Temperature		T _{stg}	-55~125	°C
焊接温度 Soldering Temperature		T _{sld}	260	°C

特性参数 Electro-optical Characteristics ($T_{amb}=25^{\circ}C$)

参数 Parameter		测试条件 Test Conditions	符号 Symbol	最小值 Min.	典型值 Typ.	最大值 Max.	单位 Units
输入端 Input	正向电压 Forward Voltage	$I_F=10mA$	V_F	-	1.2	1.4	V
	反向电流 Reverse current	$V_R=5V$	I_R	-	-	10	μA
	输入端电容 Input capacitance	$V=0,f=1kHz$	C_{IN}	-	-	250	pF
输出端 Output	断态峰值电流 Peak Off-state Current,Either Direction	$V_{DRM}=\text{Rated } V_{DRM}$ $I_F=0mA$	I_{DRM1}	-	-	500	nA
	通态峰值电压 Peak On-state Current,Either Direction	$I_{TM}=100mA \text{ peak}$ $I_F=\text{Rated } I_{FT}$	V_{TM}	-	-	2.5	V
	断态电压临界上升率 Critical Rate of Rise of Off-state Voltage	$V_{PEAK}=\text{Rated } V_{DRM}$ $I_F=0mA$	dV/dt	1	-	-	KV/ μs
	抑制电压 Inhibit Voltage	$I_F=\text{Rated } I_{FT}$	V_{INH}	-	-	20	V
	抑制状态的漏电流 Leakage in Inhibited State	$V_{DRM}=\text{Rated } V_{DRM}$ $I_F=\text{Rated } I_{FT}$	I_{DRM2}	-	-	500	μA
传输特性 Transfer Characteristics	LED 触发电流 LED trigger current	Si-3041	Terminal Voltage = 3V	I_{FT}	-	-	15
		Si-3061					
		Si-3081					
		Si-3042					
		Si-3062					10
		Si-3082					
		Si-3043					
		Si-3063					
	Si-3083	5					
维持电流 Maintain current	-		I_H	-	250	-	μA
隔离电阻 Isolation Resistance		$V_{L-O}=500V$	R_{ISO}	10^{12}	-	-	Ω
隔离电容 Isolation capacitance		$f=1MHz$	C_{ISO}	-	0.3	-	pF

典型特性曲线 Typical Characteristics Curves

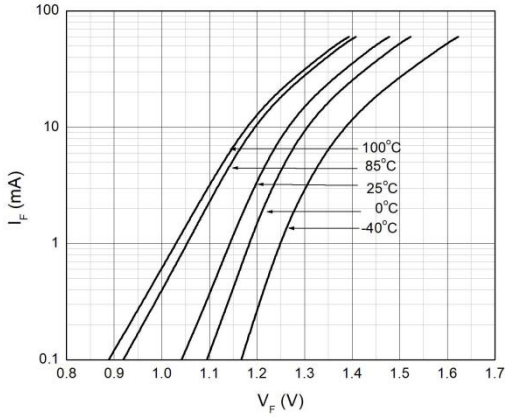

图例 1-正向电流与正向电压曲线图
 Fig. 1 - Forward Current vs. Forward Voltage

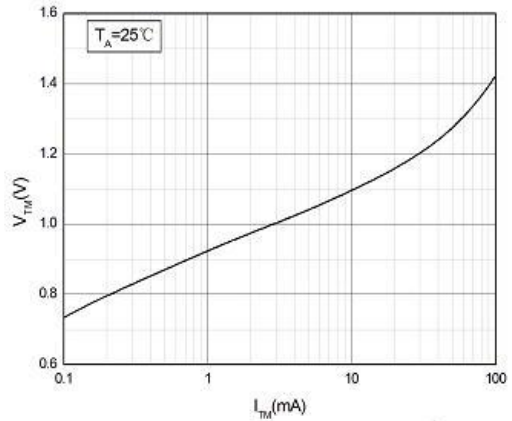

图例 2-通态特性图
 Fig. 2 - On-state Terminal Voltage vs. On-state Terminal Current

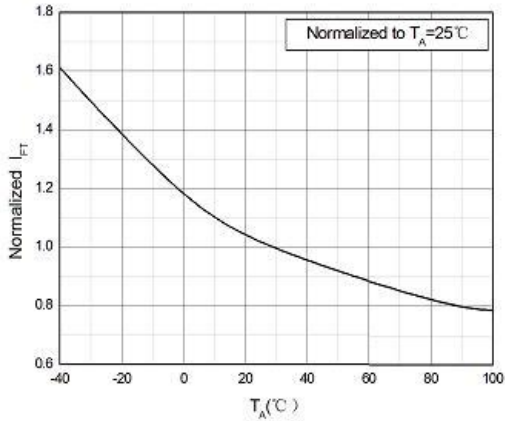

图例 3-触发电流与温度曲线图
 Fig. 3 - Normalized Trigger Current vs. Temperature

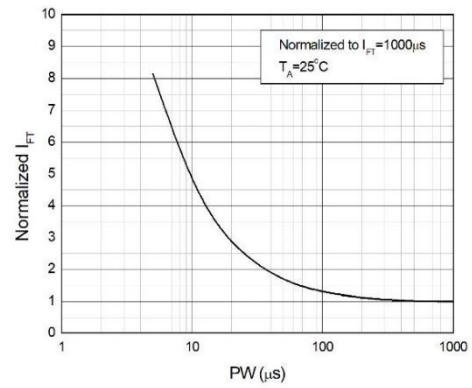

图例 4-触发电流 vs LED 脉冲宽度
 Fig. 4 Normalized Trigger Current vs. LED Trigger Pulse Width

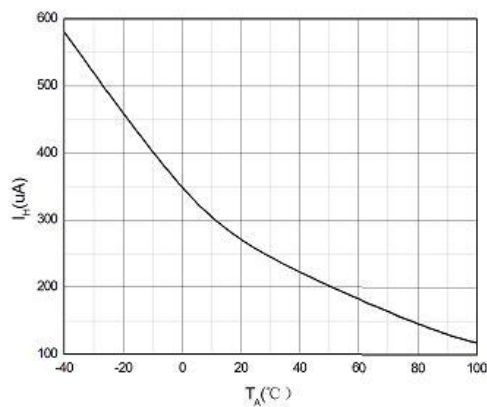

图例 5-维持电流与温度曲线图
 Fig.5-Holding Current vs. Temperature

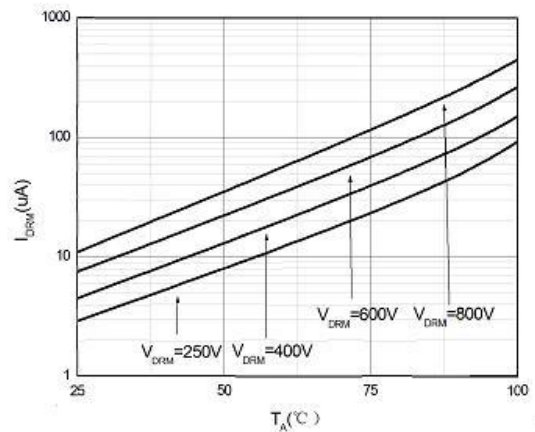

图例 6-断态峰值电流与温度曲线图
 Fig.-Off-state Terminal Current vs. Temperature

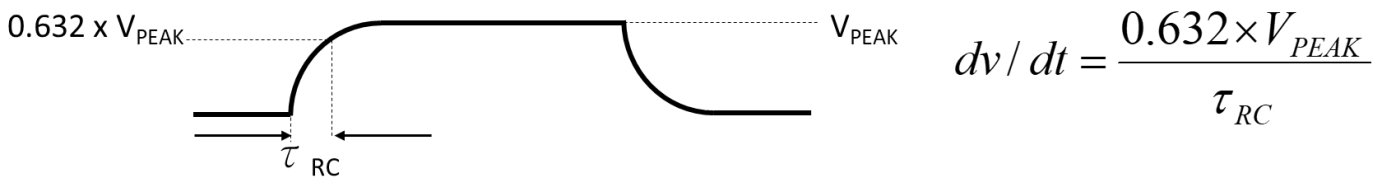
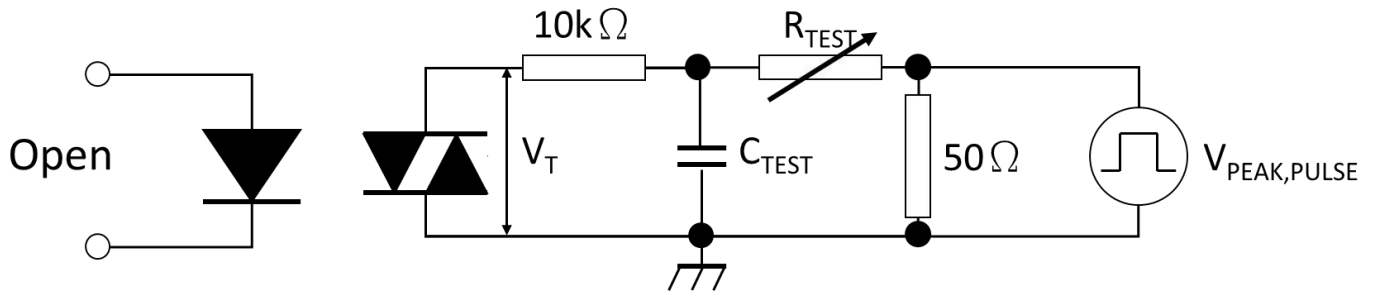

通过 RC 电路施加于被测器件的输出端的高电压脉冲设置到所需的 V_{PEAK} 值上。LED 电流无需加上。波形 V_T 使用 X100 探头监测。通过调节 R_{TEST} 值, dv/dt (斜度) 增加, 直到被测器件观察到被触发 (波形崩溃)。 dv/dt 然后下降, 直到被测器件停止被触发。此时, 记录 τ_{RC} 值并可计算 dv/dt 了。

The high voltage pulse applied to the output end of the device under test through the RC circuit is set to the desired V_{PEAK} value. LED current does not need to be added. Waveform V_T is monitored with X100 probe. By adjusting the R_{TEST} value, dv/dt (slope) increases until the device under test is observed to be triggered (waveform collapse). Dv/dt then drops until the device under test stops being triggered. At this time, dv/dt can be calculated by recording the value of τ_{RC} .

$$dv/dt = \frac{0.632 \times V_{PEAK}}{\tau_{RC}}$$

例如, QX305X 系列的电压峰值 = 400V。 dv/dt 值的计算方式如下:

For example, the voltage peak of QX305X series $V_{PEAK}=400V$. Then the dv/dt value can be calculated as follows:

$$dv/dt = \frac{0.632 \times 400}{\tau_{RC}} = \frac{252.8}{\tau_{RC}}$$

图例 7-dv/dt 测试电路

Fig.7-Test Circuits of dV/dt and Waveforms

印字信息 Marking Information

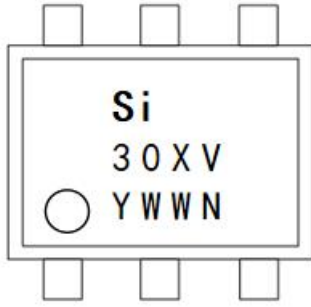

- ◆ Si:生产商代码 Manufacturer's Code Marking
- ◆ X: 代表 V_{DRM} 分档 3,4,6,8
- ◆ V: 代表 I_{FT} 分档 1,2,3
- ◆ Y: 年代码 Last Digit of Year (ex: 4=2024, 5=2025)
- ◆ WW: 周号代码 Week Code (01 to 53)
- ◆ N:特殊代码或无 Special code or None

命名规则 Naming Rule

Si-30XV-WY-ZTT

- ◆ Si: 生产商代码 Manufacturer's Code Marking
- ◆ 30XV: 器件型号代码 Device Part Number
- ◆ W:框架材质 (C=铜)
- ◆ Y:G/None (G=环保 , None =非环保)
- ◆ Z:封装 (Z=D: DIP6, Z=S: SMD6)
- ◆ TT: 补充码 A~Z or 0~9 or None

封装外形尺寸 Package Outline Dimensions

DIP6

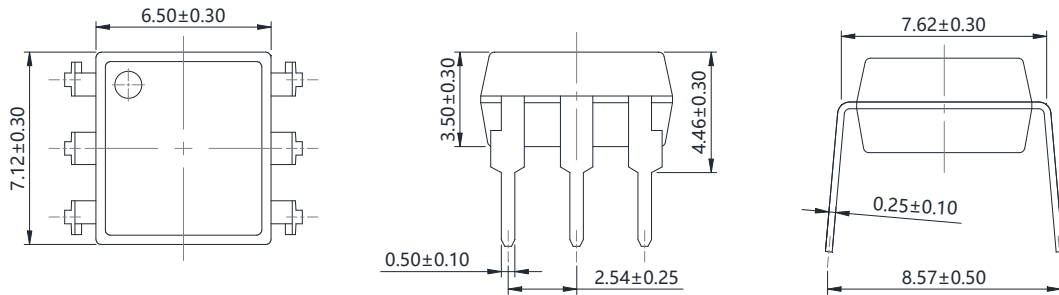

SMD6

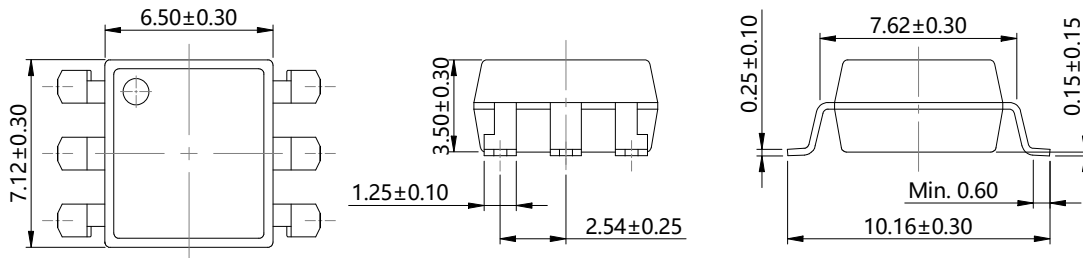

单位: mm

推荐焊盘尺寸 Recommended Footprint Patterns

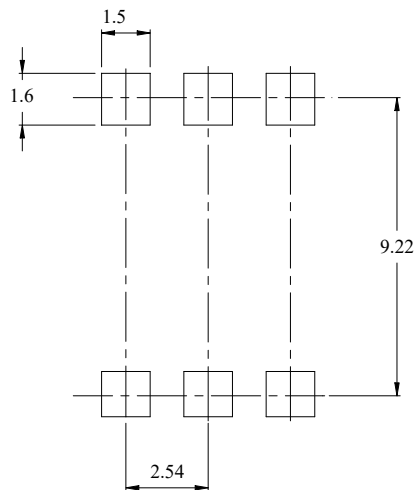

单位: mm

包装 Packing

封装类型 Package Type	每管数量 Quantity per Tube	内盒数量 Quantity per Inner Box	外箱数量 Quantity per Carton	内盒尺寸 Inner Box Dimensions	外箱尺寸 Carton Dimensions
DIP6	65pcs/tube	2080Pcs/inner box	20800pcs/carton	525*107*47mm	535*235*255mm

封装类型 Package Type	每盘数量 Quantity per Reel	内盒数量 Quantity per Inner Box	外箱数量 Quantity per Carton	内盒尺寸 Inner Box Dimensions	外箱尺寸 Carton Dimensions
SMD6	1000 pcs/reel	2000 pcs/inner box	20,000 pcs/carton	353*340*60mm	650*375*365mm

载带与卷盘 Tape and Reel

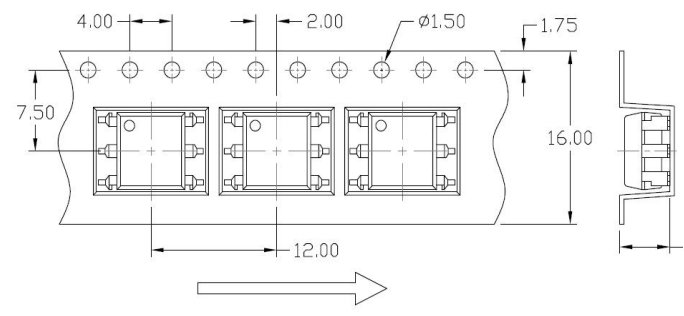
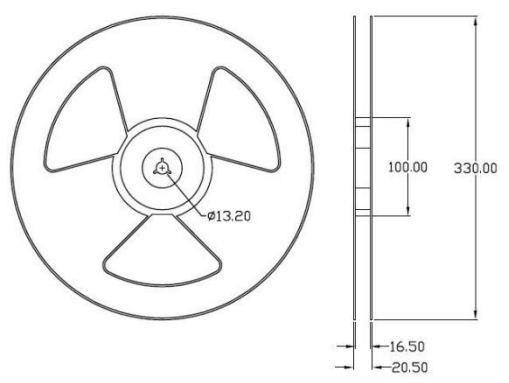
封装类型 Package Type	载带尺寸 Tape Dimensions	卷盘尺寸 Dimensions of Tape Reel
SMD6		

单位: mm

回流焊温度曲线 Solder Reflow Temperature Profile

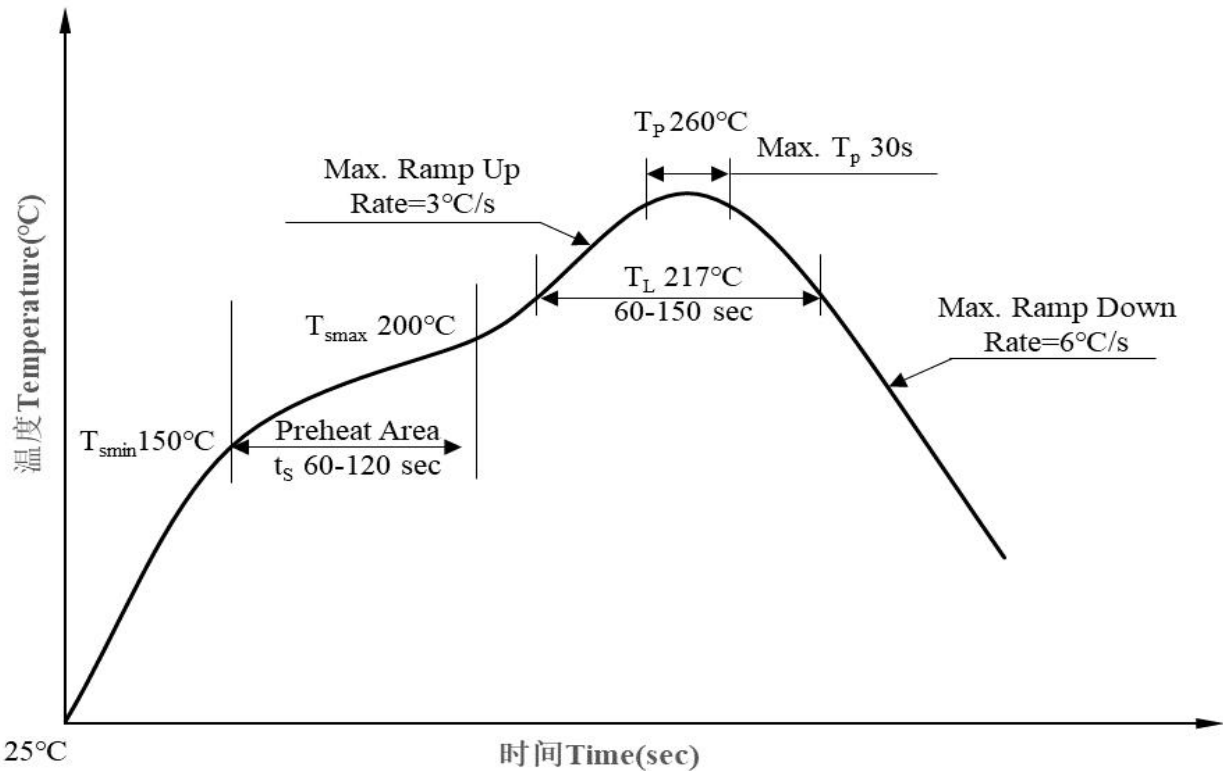

曲线项目 Profile Item		符号 Symbol	数值 Value	单位 Unit
预热区 Preheat Area	最低温度 Temperature Min.	T_{smin}	150	°C
	最高温度 Temperature Max.	T_{smax}	200	°C
	时间 Time (min. to max.)	t_s	60~120	sec
焊接区 Soldering Area	温度 Temperature	T_L	217	°C
	时间 Time	t_L	60~150	sec
峰值温度 Peak Temperature		T_p	260	°C
峰值温度 T_p 至 $T_p-5^\circ\text{C}$ 之间的时间 Time within 5 °C of Peak Temperature: $T_p - 5^\circ\text{C}$		t_p	30	sec max.
上升速率 Ramp-up rate		/	3	°C / sec max.
下降速率 Ramp-down rate		/	6	°C / sec max.

注：参考 IPC/JEDEC J-STD-020D 标准。

Note: Reference: IPC/JEDEC J-STD-020D.

建议在所示的温度和时间条件下进行回流焊，最多不能超过三次。

One time soldering reflow is recommended within the condition of temperature and time profile shown below. Do not solder more than three times.

波峰焊温度曲线 Wave soldering Temperature Profile

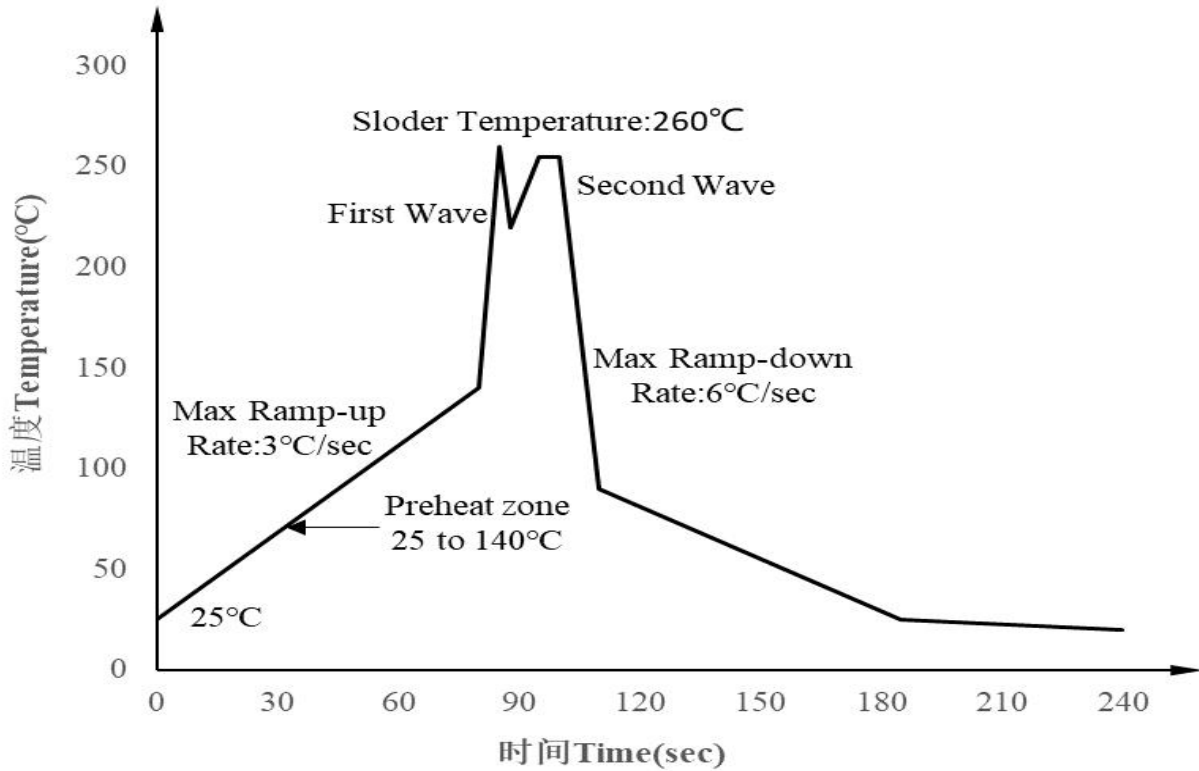

详情请参考 JEDEC 标准 JESD22-A111

For more details, please refer to the JESD22-A111 of JEDEC standards.

手工烙铁焊接 Hand soldering by soldering iron

- (1) 建议一次完成焊接。
One time soldering is recommended.
- (2) 温度 $360^{\circ}\text{C} \pm 5^{\circ}\text{C}$, 时间 $\leq 3\text{s}$ 。
Temperature: $360^{\circ}\text{C} \pm 5^{\circ}\text{C}$, within 3s.

声明 Disclaimer

1. 为提高产品可靠性、功能或设计或其他方面，硅耐所有产品规格可能会进行更改，恕不另行通知。
Silicon nice all product specifications are subject to change without notice to improve reliability, function or design or otherwise.
2. 使用本产品时请遵守规格书中的说明，硅耐对使用不符合这些规格表中说明的产品造成的损坏不承担任何责任。
When using this product, please observe the instructions in this specifications. Silicon nice assumes no responsibility for any damage resulting from use of the product which does not comply with the instructions included in this specification sheets.
3. 本规格书所展示的产品为电子应用中的一般用途而设计，如办公自动化设备、通信设备、音频/视频设备、电气应用和仪器仪表等。
The products shown in this specifications are designed for the general use in electronic applications such as office automation equipment, communications devices, audio/visual equipment, electrical application and instrumentation,etc.
4. 对于需要高可靠性或安全性的设备/装置，如太空应用、核电控制设备、医疗设备、任何“特定”应用等，请联系我们的销售代表。
For equipment/devices where high reliability or safety is required, such as space applications, nuclear power control equipment, medical equipment, any "specific" application,etc, please contact our sales representatives.
5. 如对文件中表述的内容有疑问，欢迎联系我们。
If you have any questions about the contents of the document, please contact us.